



Easy Step  
by Step  
Guide

# DIY DECK GUIDE

Planning your Project | Simple Illustrations | Hints

TIMBERLINK. MADE OF TASMANIA.

# DIY Deck Guide

The specifications contained within this brochure are for guideline purposes only. For further information contact a registered consulting engineer and or your local shire council.

By following a straight forward program you can build an attractive and long lasting deck with the minimum of effort and using only a few basic wood-working tools.

Timberlink Green is the ideal material for external, above-ground structural applications, like a deck's substructure. It is dimensionally stable, easy to use and made in Tasmania from Tasmanian grown plantation pine.

## General Hints

When you have planned your deck it is advisable to consult your local council to ensure the structure conforms to local government regulations. An elevated deck needs to be designed so that it is capable of taking expected loads. Generally decks require building approval and you will need to consult with a registered engineer to provide engineer drawings and certification.

Consider the size and use of your deck. If it is to be used for dining there needs to be plenty of room for tables and chairs

It is also important to make sure that the deck does not interfere with existing drainage, plumbing or electricity services.

Where footings are in proximity to council sewer and or stormwater it may be necessary to complete a build over or near a sewer or stormwater application. Check with your local shire council, certifier or engineer for further details.



## Timberlink Decking Range

Our Bell Bay mill, using Tasmanian Plantation Pine, makes everything you need to build your deck; our Low Odour Timberlink Green Outdoor Structural timber for the bearers and joists, Timberlink Posts and Timberlink Decking Boards to finish it off.

Download a copy of our product catalogue at [madeoftasmania.com.au](http://madeoftasmania.com.au) to see our full range.

### ☑ Tools checklist:

- Tape measure, Square, Pencil
- Hammer and Chisel
- Spirit level, plumb bob
- String line, String level
- Crowbar and Shovel
- Circular saw or Hand saw
- Power drill with bits
- 12mm masonry bit
- Spanner for 12mm bolts/ nuts
- Endseal preservative
- Galvanised fasteners

# Planning Your Project

## Timber Selection Guide

Hazard Class	Typical Uses	
<b>H3</b> Outside, above ground	Decking, cladding, fascia, window joinery, exterior structural timber (above ground), engineered wood products	
<b>H4</b> Outside, in ground	Pergolas, posts, greenhouses	

Hazard Class Selection Guide AS1604

## Before You Start

- > Check there are no drainage problems in the area where you plan to build your deck.
- > Mark out the site accurately and ensure it is square. Mark out locations of posts.
- > Work out the number of bearers and joists required, refer Table 1 Bearers and Table 2 Joists. These tables will aid your engineer in designing the deck framing and provide you with a good basis for estimating the cost.
- > Decks can be raised or built on the ground. The design should maximize airflow through and around the construction. Raised decks should be adequately braced.
- > Raised decks can be free standing or attached to an existing structure. If the deck is to be attached to an existing structure, the existing structure should be checked and verified by a registered engineer to ensure that it is structurally adequate to sustain the added load of the deck.

## Notes

- > This guide assumes an M-site classification as per the Australian standard for residential slabs and footings AS2870-2011 with a minimum bearing capacity of 100kPa.
- > You should consult a registered geotechnical and or civil/ structural engineer to confirm the site classification and bearing capacity of the site prior to you commencing any works.
- > If the site classification differs from an M-site (i.e moderately reactive) and or the bearing capacity is less than a 100 kPa it will be necessary to engage a registered civil/ structural engineer to design the footings.
- > This guide assumes a wind classification of N2 which is a common classification for dense residential areas.
- > You should engage a registered civil structural engineer to confirm the wind classification for your individual site.



# Easy Step by Step Guide

## Setting out Foundations

Mark out the site accurately and ensure it is square.

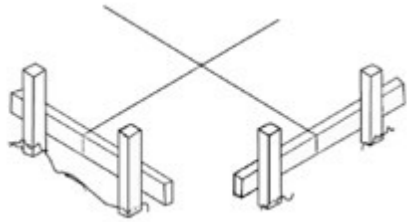

### For Groundline Decks

Do not lay ground level decks directly onto grass. Remove all turf and cover the ground with permeable membrane or polythane (with holes pierced) and gravel to prevent weeds growing.

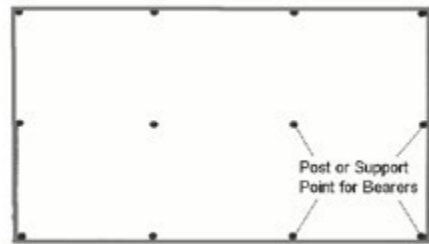

Lay the framing on concrete slabs bedded into position or on existing level concrete slabs.

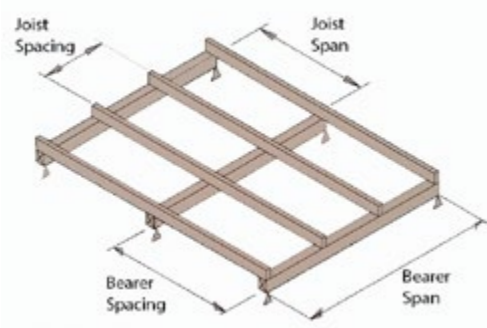

### For Raised Decks

Posts for raised decks should be 100 x 100mm treated pine posts, at max. 1800mm centres, and embedded using concrete.

## 1. Timberlink Bearers (Max. 1800mm Spacing)

Timber Grade, Species	Member Size (mm)	Maximum Bearer Span (mm)
F7	140x45	1300
Timberlink Green	2/140x45	1900
	190x45	1750
	2/190x45	2600
	240x45	2450

\*Table developed for a live load of 2kPa.

## 2. Timberlink Floor Joists (Max. 450mm Spacing)

Timber Grade, Species	Member Size (mm)	Maximum Floor Joist Span (mm)
F7	90x45	1400
Timberlink Green	140x45	2200*
	190x45	3200*
	240x45	4200*

\*Single span however the bearer spacing above is not applicable and you should consult a registered engineer for appropriate bearer sizes. Table developed for a live load of 2kPa.



## Setting Posts

First establish post spacing and embedment depth. Then mark out and dig the holes for the uprights.

Hole Diameters:  
Up to 250mm posts - dig 450mm diameter holes.

Dig post holes to a depth of 900mm.

Set posts as shown using concrete. The posts should be stood and temporarily braced before setting. Check the height, alignment using string lines and a level.

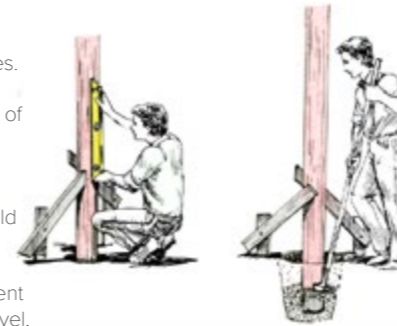

**CONCRETE EMBEDMENT**  
Use minimum 25mPa concrete for concrete footings

Carry concrete above ground water level and angle to shed water runoff.

Dig Post holes at least 200mm greater in width than the post.

Dig 100mm over deep and layer with 100mm of coarse hard fill for drainage.

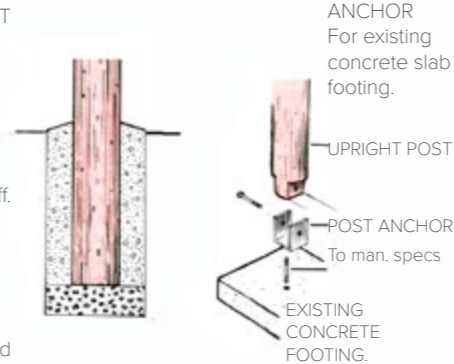

Create stunning outdoor living spaces with Timberlink's Tasmanian plantation pine decking and screening.

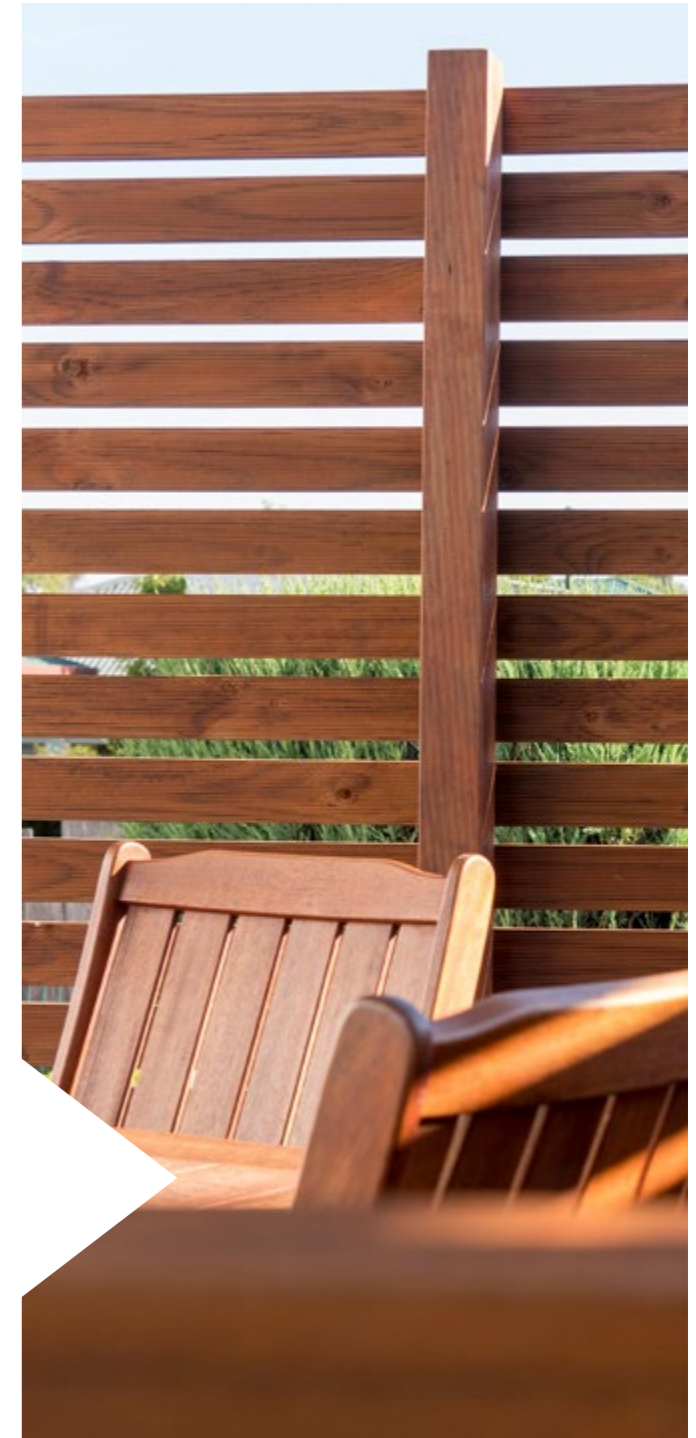

# Easy Step by Step Guide

## Building the Subframe

Once posts have been set, mark out levels on posts for bearers. Attach bearers to the posts using 2/M12 bolts grade 4.6S.

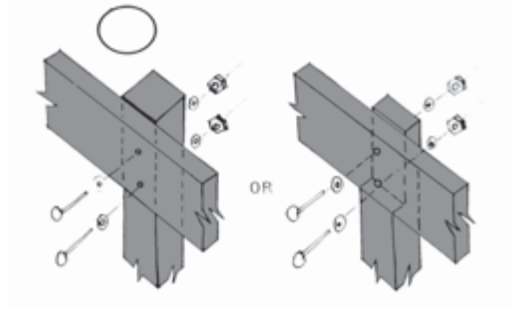

Fix joists to the bearers at max. 450mm spacing using triple grips or joist hangers, as shown in example below, and in accordance with manufacturers specifications.

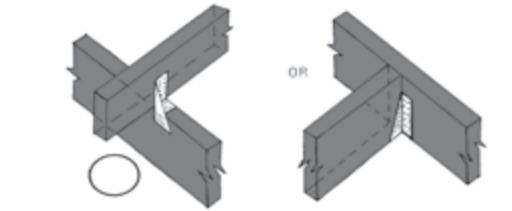

When decks are to be attached to the side of the house, using a ledger bearer, the ledger bearer should be bolted to the wall at max. 600 centres using 2/M12 bolts grade 4.6S, to support and carry the load of the joists. It will be necessary to engage a registered structural engineer to advise on the structural adequacy of the existing support structure.

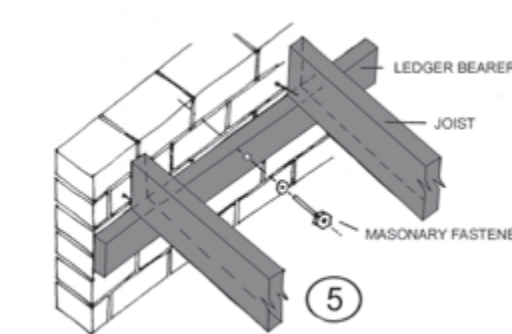

Noggings (offcuts of joists) are used to prevent the joists from twisting or buckling. These are attached 90° to the joist in a staggered pattern at 1200mm centres.

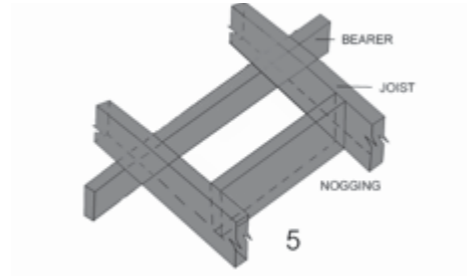

Raised decks should be adequately braced at corners using two sets of 2 diagonal timbers at one corner, fixed from the top of one post to the bottom of the next. Timbers should be fixed using a galvanised 12mm bolt (see below). Depending upon the size of the deck it may be appropriate to only brace one corner. Consult a registered structural engineer for further advice.

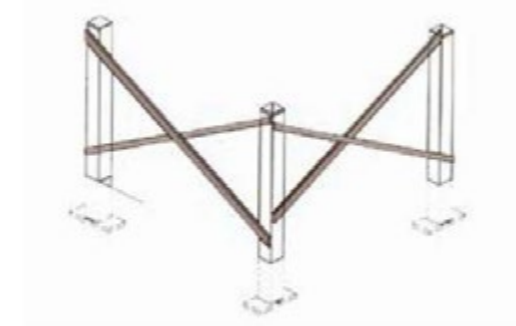

For additional protection against moisture and weathering, a flexible PVC barrier can also be installed to the top side of the bearers and joists.

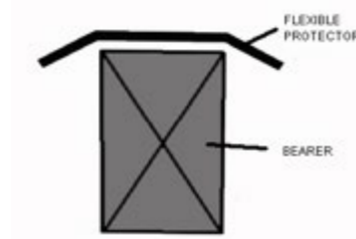

For more DIY projects visit us at [madeoftasmania.com.au](http://madeoftasmania.com.au)

## Safety and Handling

When handling and cutting any timbers it is advisable to wear dust masks, goggles and gloves. **Do not burn any treated timber.** Safety Data Sheets (SDSs) are available from [timberlinkaustralia.com.au](http://timberlinkaustralia.com.au)

## Waste Disposal

Timberlink Green products are not classified hazardous by Safe Work Australia. However we recommend that you check with your local authority to determine the correct disposal methods.

Treated timber products should never be used for composting or animal bedding and should never be burned.

## Disclaimer:

These specifications are for guideline purposes only. As conditions vary from one site to another it is strongly recommended that you consult with a registered consulting engineer and your local shire council. These plans have been checked and approved (at the time of printing) by Civil & Structural consulting engineers Roy B Hoskins & Associates of QLD 4060, to be technically accurate and generally designed in accordance with the appropriate Australian Standards. As the Australian standards, local, state and national laws are subject to change, please check with your local authorities prior to starting construction.

Always refer to product safety data sheets for full health and safety instructions.

These can be downloaded from [timberlinkaustralia.com.au/safety-data-sheets-sds](http://timberlinkaustralia.com.au/safety-data-sheets-sds)



**TIMBERLINK. MADE OF TASMANIA.**

[madeoftasmania.com.au](http://madeoftasmania.com.au)





**TIMBERLINK**<sup>®</sup>  
Australia